

## New Data Acquisition Systems Communicate with Microprocessors Over 4 Wires

As board space and semiconductor package pins become more valuable, serial data transfer methods between microprocessors (MPUs) and their peripherals become more and more attractive. Not only does this save lines in the transmission medium, but, because of the savings in package pins, more function can be packed into both the MPU and the peripheral. Users are increasingly able to take advantage of these savings as more MPU manufacturers develop serial ports for their products. However, peripherals which are able to communicate with these MPUs must be available in order for users to take full advantage. Also, MPU serial formats are not standardized so not all peripherals can talk to all MPUs.

### The LTC1090 Family

A new family of 10-bit data acquisition circuits has been developed to communicate over just 4 wires to the recently developed MPU synchronous serial formats as well as to MPUs which do not have serial ports. These circuits feature software configurable analog circuitry including analog multiplexers, sample and holds, bipolar and unipolar conversion modes. They also have serial ports which can be software configured to communicate with virtually any MPU. Even the lowest grade device features guaranteed  $\pm 0.5$ LSB linearity over the full operating temperature range. Reduced span operation (down to 200mV), accuracy over a wide temperature range and low power single supply operation make it possible to locate these circuits near remote sensors and transmit digital data back through noisy media to the MPU. Figure 1 shows a typical hookup of the LTC1090, the first member of this data acquisition family. For more detail, refer to the 24-page LTC1090 data sheet.

Included are eight analog inputs which can common-mode to both supply rails. Each can be configured for unipolar or bipolar conversions and for single-ended or differential inputs by sending a data input ( $D_{IN}$ ) word from the MPU to the LTC1090 (Figure 1).

Both the power supplies are bypassed to analog ground. The  $V^-$  supply allows the device to operate with inputs which swing below ground. In single supply applications it can be tied to ground.

The span of the A/D converter is set by the reference inputs which, in this case, are driven by a 2.5V LT1009 which gives an LSB step size of 2.5mV. However, any reference voltage within the power supply range can be used.

The 4 wire serial interface consists of an active low chip select pin ( $\overline{CS}$ ), a shift clock (SCLK) for synchronizing the data bits, a data input ( $D_{IN}$ ) and a data output ( $D_{OUT}$ ). Data is transmitted and received simultaneously (full duplex), minimizing the transfer time required.

The external ACLK input controls the conversion rate and can be tied to SCLK as in Figure 1. Alternatively, it can be derived from the MPU system clock (e.g., the 8051 ALE pin) or run asynchronously. When the ACLK pin is driven at 2MHz, the conversion time is 22 $\mu$ s.

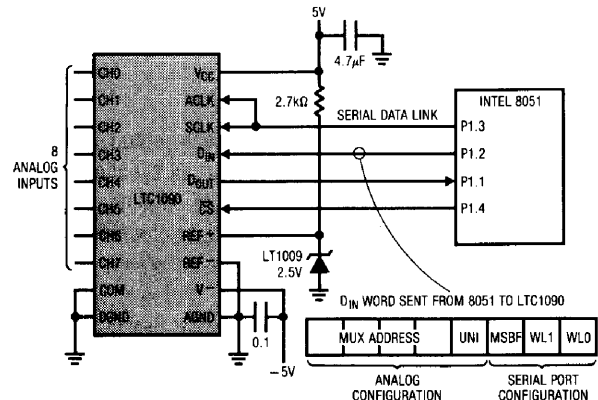

Figure 1. A Typical Hookup of the LTC1090

### Advantages of Serial Communications

The LTC1090 can be located near the sensors and serial data can be transmitted back from remote locations through isolation barriers or through noisy media.

Several LTC1090s can share the serial interface and many channels of analog data can be digitized and sent over just a few digital lines (see Figure 2). This could, for example, be used to simplify the communications between an instrument and its front panel.

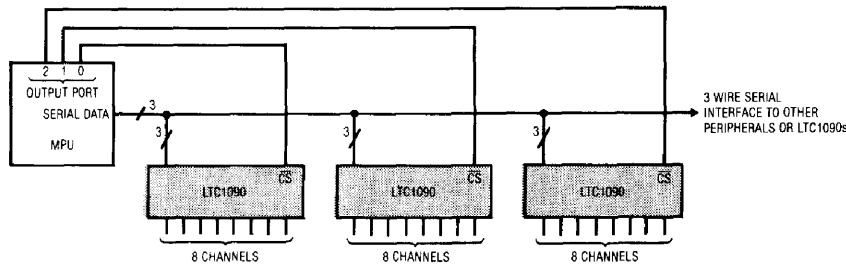

Figure 2. Several LTC1090s Sharing One 3 Wire Serial Interface

Using fewer pins for communication makes it possible to pack more function into a smaller package. LTC1090 family members are complete systems being offered in packages ranging from 20 pins to 8 pins (e.g., LTC1091).

### Speed is Usually Limited by the MPU

A perceived disadvantage of the serial approach is speed. However, the LTC1090 can transfer a 10-bit A/D result in  $10\mu\text{s}$  when clocked at its maximum rate of 1MHz. With the minimum conversion time of  $22\mu\text{s}$ , throughput rates of 30kHz are possible. In practice, the serial transfer rate is usually limited by the MPU, not the LTC1090. Even so, throughput rates of 20kHz are not uncommon when serial port MPUs are used. For MPUs without serial ports, the transfer time is somewhat longer because the serial signals are generated with software. For example, with the Intel 8051 running at 12MHz, a complete transfer takes  $80\mu\text{s}$ . This makes possible throughput rates of approximately 10kHz.

### Talking to Serial Port MPUs

By accommodating a wide variety of transfer protocols, the LTC1090 is able to talk directly to almost all synchronous serial formats. The last 3 bits of the LTC1090 data input ( $D_{IN}$ ) word define the serial format. The MSBF bit determines the sequence in which the A/D conversion result is sent to the processor (MSB or LSB first). The two bits WL1 and WL0 define the word length of the LTC1090 data output word. Figure 3 shows several popular serial formats and the appropriate  $D_{IN}$  word for each. Typically a complete data transfer cycle takes only about 15 lines of processor code.

### Talking to MPUs without Serial Ports

The LTC1090 talks to serial port processors but works equally well with MPUs which do not have serial ports. In these cases,  $\overline{CS}$ , SCLK and  $D_{IN}$  are generated with software on 3 port lines.  $DO_{UT}$  is read on a fourth. Figure 3 shows the appropriate  $D_{IN}$  word for communicating with MPU parallel ports. Figure 1 shows a 4 wire interface to the popular Intel 8051. A complete transfer takes only 33 lines of code.

### Sharing the Serial Interface

No matter what processor is used, the serial port can be shared by several LTC1090s or other peripherals (see Figure 2). A sepa-

rate  $\overline{CS}$  line for each peripheral determines which is being addressed.

### Conclusions

The LTC1090 family provides data acquisition systems which communicate via a simple 4 wire serial interface to virtually any microprocessor. By eliminating the parallel data bus they are able to provide more function in smaller packages, right down to 8 pin DIPs. Because of the serial approach, remote location of the A/D circuitry is possible and digital transmission through noisy media or isolation boundaries is made easier without a great loss in speed.

Hardware and software is available from the factory to interface the LTC1090 to most popular MPUs. The LTC1090 data sheet contains source code for several microprocessors. Further applications assistance is available by calling the factory.

LTC1090 $D_{IN}$ Word						
Type of Interface	LTC1090 Data Format	Analog Configuration	MSBF	WL1	WL0	
All Parallel Port MPUs	MSB First 10 Bits	X X X X X	1	0	1	
National MICROWIRE* MICROWIRE/PLUS*	MSB First 16 Bits	X X X X X	1	1	0	
Motorola SPI		X X X X X	1	1	1	
Hitachi Synchronous SCI	LSB First 16 Bits	X X X X X	0	1	1	
TI TMS7000 Serial Port		X X X X X	0	1	1	

Figure 3. The LTC1090 Accommodates Both Parallel and Serial Ports

\*MICROWIRE and MICROWIRE/PLUS are trademarks of National Semiconductor Corp.

### Bibliography

- [1] Aleef, Abdul, and Richard Lazovick, "Microwire/Plus," National Semiconductor, Santa Clara, CA, Wescon '86, Session 21.
- [2] Derkach, Donald J., "Serial Data Transmission in MCU Systems," RCA Solid State, Somerville, NJ, Wescon '86, Session 21.
- [3] Kalinka, Theodore J., "Versatile Serial Peripheral Interface (SPI)," RCA Solid State, Somerville, NJ, Wescon '86, Session 21.

For LTC1090 literature call 800-637-5545. For help with an application call (408) 432-1900, Ext. 361.

Linear Technology Corporation  
1630 McCarthy Boulevard  
Milpitas, CA 95035-7487

